

**PACT MODEL 1 CHRONOGRAPH**  
**Users Manual**  
**Copyright P.A.C.T. Inc. 1992**

To begin with familiarize yourself with your Model 1. Note the on/off switch and skyscreen inputs on the back of the unit, marked ``Start" and ``Stop", as well as the 9 volt battery compartment. All PACT Products share the same back panel so don't be surprised to find a few extra holes in the back of your machine. These are used for the stop plate inputs on the PACT MKIII Championship Timer and do not affect the operation of your Model 1 Chronograph. The control buttons are located on the front panel. They control the Edit and Review functions (more about those later) and are used together to begin a new string.

## **THE BATTERY**

Your Model 1 uses a standard 9 volt Alkaline battery. Battery life will vary with the quality of the battery (Duracell Alkaline seem to be the best) and the light level of the sky. The brighter the sky the more current the skyscreens will draw. In addition you will get more total "on" hours out of a battery by turning your chronograph off between strings, although the cost savings may not be worth the hassle.

As the battery runs down the sensitivity of the skyscreens will begin to drop and the display will begin to grow faint. Keep in mind that the computer in your Model 1 requires far less power to run than the skyscreen/detector system. On very cold days you might consider keeping an extra battery in warm your pocket and trading them out as the battery in your machine freezes. On the other hand if it's that cold outside you might be better off staying home with your sweetheart and enjoying a hot buttered rum while you supervise her loading your ammo.

## **SKYSCREENS**

Your Model 1 comes equipped with the finest Skyscreens on the market. The new PACT MKV Professional Skyscreen contains two lenses that serve to magnify the bullet and bring it into sharp focus. This provides more accurate triggering at a given range than un-lensed skyscreens. The diffuser screens provide serve as both an aiming guide and light diffuser. (On blue sky sunny days they make it easier for the chronograph to see the bullet by providing a portable cloud for the sun to eliminate.)

If you have our optional skyscreen mounting bracket just screw the skyscreens to it as shown in the illustration. The skyscreens should fit snugly against the cross pieces to insure proper screen separation. The center of the bracket is threaded for a

standard camera tripod (1/4-20). If you have one this is a pretty good way to go although you can set the bracket on any flat surface.

If you are fabricating your own mounting bracket take care to insure that the screens are precisely 24 inches apart, center to center. Whatever % error you make in screen separation will result in the same % error in velocity readings.

Fit the side pieces into the cross piece and slip the unit into the skyscreen. When you have done this to each skyscreen the completed package should look like this:

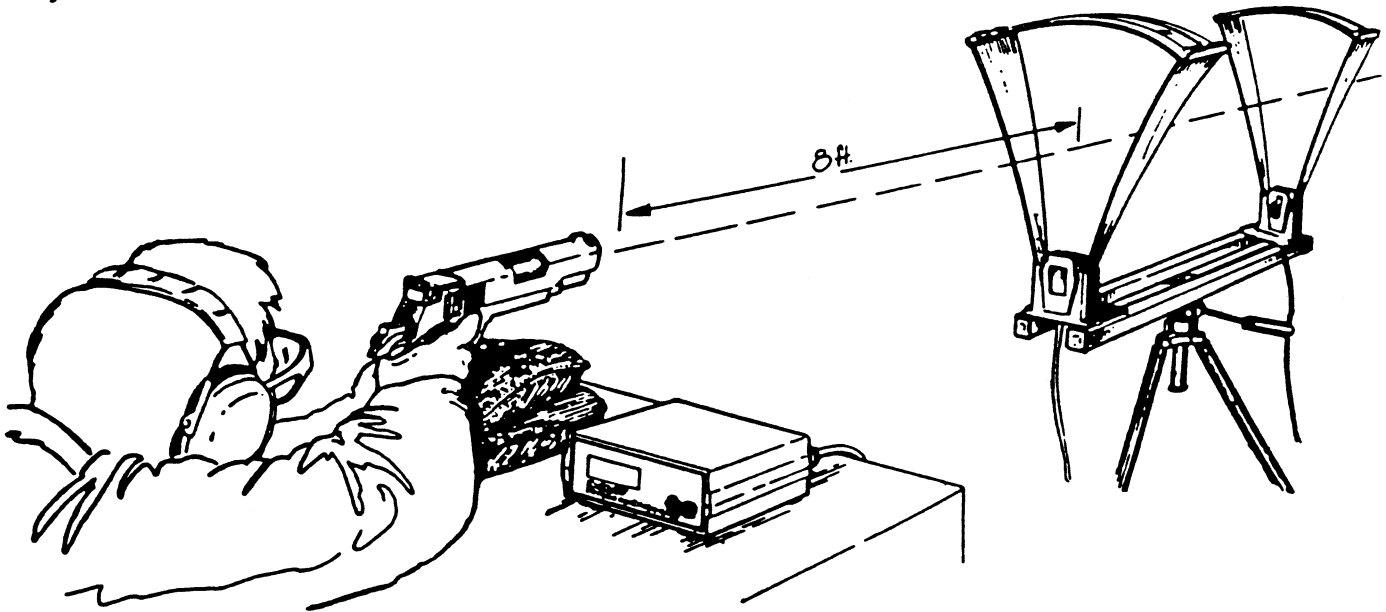

The first skyscreen the bullet will pass over should be plugged into START, the second screen should be plugged into STOP.

When you fire you should aim in such a way that the bullet passes over the center of both screens at 5 to 8 inches above them. Under most light conditions you can actually shoot higher than this and still get reading but their accuracy may diminish slightly as you shoot higher. Under poor conditions, such as late afternoon or early morning in the winter or a very dark gloomy day, you may have to shoot lower in order to get readings.

## **LET'S CHRONOGRAPH SOME LOADS**

Set your skyscreens up making sure that they are pointed in a safe direction. Place your Model 1 where you can read it at a glance and turn it on. It will display:

PACT, followed by  
24 in, followed by  
FIRE

This tells you that it is ready to go and assumes that the screens are exactly 24 inches apart. Press the Review button and the Model 1 will say ``NONE" indicating that there is nothing in memory to review. Press Edit and the Model 1 will respond with ``NO" because there is nothing to edit yet. The display will now read:

**FIRE**

Your Model 1 is now waiting for you to shoot.

**MAKE SURE YOU HAVE YOUR SHOOTING GLASSES ON - IF YOU HIT A SKYSCREEN OR THE BRACKET HOLDING IT, BITS OF PLASTIC, METAL AND BULLET WILL FLY IN ALL DIRECTIONS.**

**DON'T PUT METAL PLATE IN FRONT OF YOUR SKYSCREENS**

Go ahead and fire a round over your skyscreens. The Model 1 should display something like:

01 (the shot number), alternating with 2456 (the velocity in FPS)

If it does not, make sure that the first screen is plugged into START and the second screen is plugged into STOP. If this checked out you probably missed the "window". Try again, remember 5 to 8 inches over the center of the screens.

*Note that you must wait about 1 second between shots, we make you do this to allow the smoke to clear. If you fire too soon you will either get no reading, an error (ERR) warning or a very odd reading like 10 fps. Remember give it a second between shots.*

Go ahead and fire a few more shots. Each time you fire, the current shot number and velocity will alternate on the display.

If you notice a bad reading, push the EDIT button. This will erase the last shot from the computer's memory and back the display up to the previous shot. You can also use this feature after you have finished your string so don't feel like you have to fuss with your Model 1 in the middle of a string.

When you are done with your string, the Model 1 will provide you with a statistical summary. Each time you push the review key the Model 1 will move to the next item of the review. The display will alternate between the statistic shown, such as ``SD" for Standard Deviation, and the number. Here is an example of what you would see if you went through the entire review of a 5 shot string.

``HI" 2562 (the highest velocity of the string)

``LO" 2490 (the lowest velocity of the string)

``AV" 2520 (the average velocity of the string)

``ES" 72 (the extreme spread of the string)

``SD" 23 (the standard deviation of the string)

``AD" 21 (the average deviation or Mean Absolute Deviation of the string)

At this point each shot of the string (up to 20) can be individually reviewed. If you see a bad reading just push the edit button. After the last shot is reviewed push the review button again and you'll see that the statistics have been recalculated, without the shots you edited out. Two important points to remember when reviewing:

1. The chronograph will not record shots when it's in review mode.
2. You can get out of review mode at any time by pressing the Review and Edit buttons together. The Model 1 will respond with ``FIRE" indicating that it has cleared its memory and is ready to begin a new string.

## **HOW IT WORKS**

Each skyscreen contains a photo-transistor which is constantly measuring the current light level. Because the bullet is darker than the sky, when a bullet goes over the skyscreen the light level drops a little bit. The amplifier inside your Model 1 takes note of this drop in light level and amplifies it to the point that the drop is big enough for the computer to notice. The computer then times how long it took for the bullet to travel from the first screen to the second screen where the light level again drops. Accurately converting this time into a velocity is easy, provided the computer knows how far apart the screens are. The Model 1 always tells you the skyscreen separation it is looking for when you turn it on.

## **LIGHT CONDITIONS**

Many light sensitive chronographs have a reputation for being flaky under certain light conditions. We have gone to great lengths to minimize this problem, but you may still occasionally run into a combination of conditions that may make it hard for your chrono to read correctly. It will help if you develop an understanding of how your chronograph works.

Your PACT Model 1 is looking for a decrease in light level when the bullet passes over the skyscreen. Assuming that enough light was entering the skyscreen to begin with, your Model 1 will always get an accurate reading. If, on the other hand, the

light level increases as the bullet crosses the skyscreen, you will probably get no reading at all.

How could the light level increase? Let's say that you are chronographing under a dark blue sky and that the sun is reflecting brightly off of the bullet. Now the bullet is actually brighter than the sky above it. When it crosses over the skyscreen the light level goes up instead of down, thus we get no reading. Note that with a slow bullet like a 45 ACP fired under these conditions you may still get a reading. This is because the bullet may be over the screen long enough for the bullet to be considered the "normal" light condition. When the bullet leaves the light level drops and triggers the computer. This will still give you an accurate reading, but it is not "ideal".

By using the diffuser provided with your Model 1 you can eliminate most of these troubles. The diffuser acts like a portable overcast day. Assuming the sun is hitting it, it will actually provide a "sky" that is 200% to 400% brighter than the blue sky above it.

If the sun is low in the sky and is illuminating the underside of the bullet your Model 1 may have a hard time seeing it even when using the diffuser screens. If this happens you might try shooting lower over the skyscreens. You may also eliminate the problem by changing the light conditions. Put a shade to the **side** of your screens so that the bullet is in the shade when it crosses over the skyscreens, thus increasing the **contrast** in light level between the bullet and the sky. You might also try changing the direction of fire and/or tilting your skyscreens. Remember we are trying to get as big a contrast between the bullet and the sky as possible.

When operating on an overcast day the diffusers will not do any thing for you (other than act as an aiming guide. If it's a very dark overcast day and you find your self having trouble getting reading try removing them altogether.

## **MUZZLE BLAST**

Most of our original customers were pistol shooters and we have gone to some lengths to filter out muzzle blast. Unfortunately if we filter it out completely your chronograph would not see bullets either. When you fire a subsonic (below around 1200 FPS) round, the sound of the gun reaches the skyscreens before the bullet does. If it shakes the screens hard enough they will trigger and give you an incorrect reading. For example, let's say that you are firing a .45 ACP at 850 FPS and find that your Model 1 is telling you that your round is going 680 FPS. What's happening is that the muzzle blast is triggering the start screen before the bullet gets there, but it lacks sufficient power to trigger the stop screen by the time its traveled that far. So we have a situation where the blast started the computer and bullet stopped it, hence the low reading. If the blast is severe enough to trigger both screens, you will be measuring the speed of sound instead of your bullet velocity. In either case the solution is simple:  
**BACK UP!**

When you fire a supersonic round the bullet gets to the skyscreen before the blast does. Keep the muzzle a few feet back from the first skyscreen to keep from beating it up. Remember that the farther your screens are from the muzzle the lower the velocity your chronograph will read (the bullet starts slowing down as soon as it leaves the barrel). If the blast is severe enough the gas from the cartridge (which proceeds the bullet for the first few feet of travel) may trigger the start screen and cause erroneous readings.

Another muzzle blast problem occurs when the skyscreens trigger on the **shadow of the muzzle blast**. This can happen when the sun is quartering to directly behind you and fairly low on the horizon (otherwise known as shooting north in the winter months). What happens is that you have a fairly dark blue sky, so the Glint Guard turns up its sensitivity. The sun is reflecting off the edge of the slit in your skyscreen. When you fire, your muzzle blast expands rapidly outward and as it crosses the line between the sun and your skyscreen the amount of light impacting the edge of the skyscreen slit drops producing an absurdly high reading (like 2700 FPS for your rimfire 22 pistol). Changing the direction of fire **will** solve the problem. If the fellow firing next to you causes your chronograph to trigger this is probably the culprit.

## **PROBLEMS**

Hopefully you won't have any problems with PACT Model 1. We have busted our rears to make this thing as reliable as possible. Of course every so often a capacitor dies, a resistor breaks or an integrated circuit does whatever it does when it dies. These things don't happen very often and we go to great lengths to see to it that we only use the best possible components. If your Model 1 does misbehave, here are some thing to check:

Are the screens plugged in correctly?

Is the battery up to speed? When it gets low on power your Model 1 will get less sensitive. For example it may have trouble seeing a bullet although it may still pick up your hand.

Is the bullet darker than the sky? If it's not, the Model 1 will have a hard time seeing it. You might try shooting lower over he screen.

Water can reek havoc inside your skyscreens. If you leave them out in the rain they will fill with water which will short out the photo transistor. If this happens, it may be necessary to take them apart to dry them out. You probably won't leave them out in the rain twice.

If you do have a problem, for goodness sake, **DON'T SUFFER IN SILENCE!** Call us. Our success depends on your satisfaction. We have been building electronic products for shooters for years. We will get you sorted out.

## **ODDS AND ENDS**

How do you know if your Model 1 is telling you the truth? If the reading you get is close to what it should be you can count on it being within .5%. That's point five per cent **not** five percent. Normally you will find that the reading are actually better than that. If the unit prints a bad velocity it should be off by enough to be obviously wrong. Bright overcast days will produce more accurate and consistent readings than blue sky sunny days.

In almost six years of chronograph building we have yet to have a unit returned for repair because it read too high. However about once a month a member of the Magnum/Weatherby club has us "check his unit out" because it reads "200 feet low." While we have seen a few bad counter chips, out of thousands of chronographs tested, it is dam near impossible for a unit to read "200 feet low" with one cartridge and correct with another.

If you want to compare two chronographs you should set them up so that a single shot registers on both units. We recommend that you compare average velocities on 10 shot strings. To compare the "Variability" of one chronograph to another compare the SD's or MAD's (if available) recorded on each string on each chronograph. If chronograph "A" has a 10% lower SD or MAD **on the same string** as chronograph "B" than you can correctly say that chronograph "A" has a slightly lower "total system error."

**DON'T BE A DUMB ASS!**  
**ALWAYS WEAR EYE PROTECTION!**

## PACT MKS Professional Skyscreen

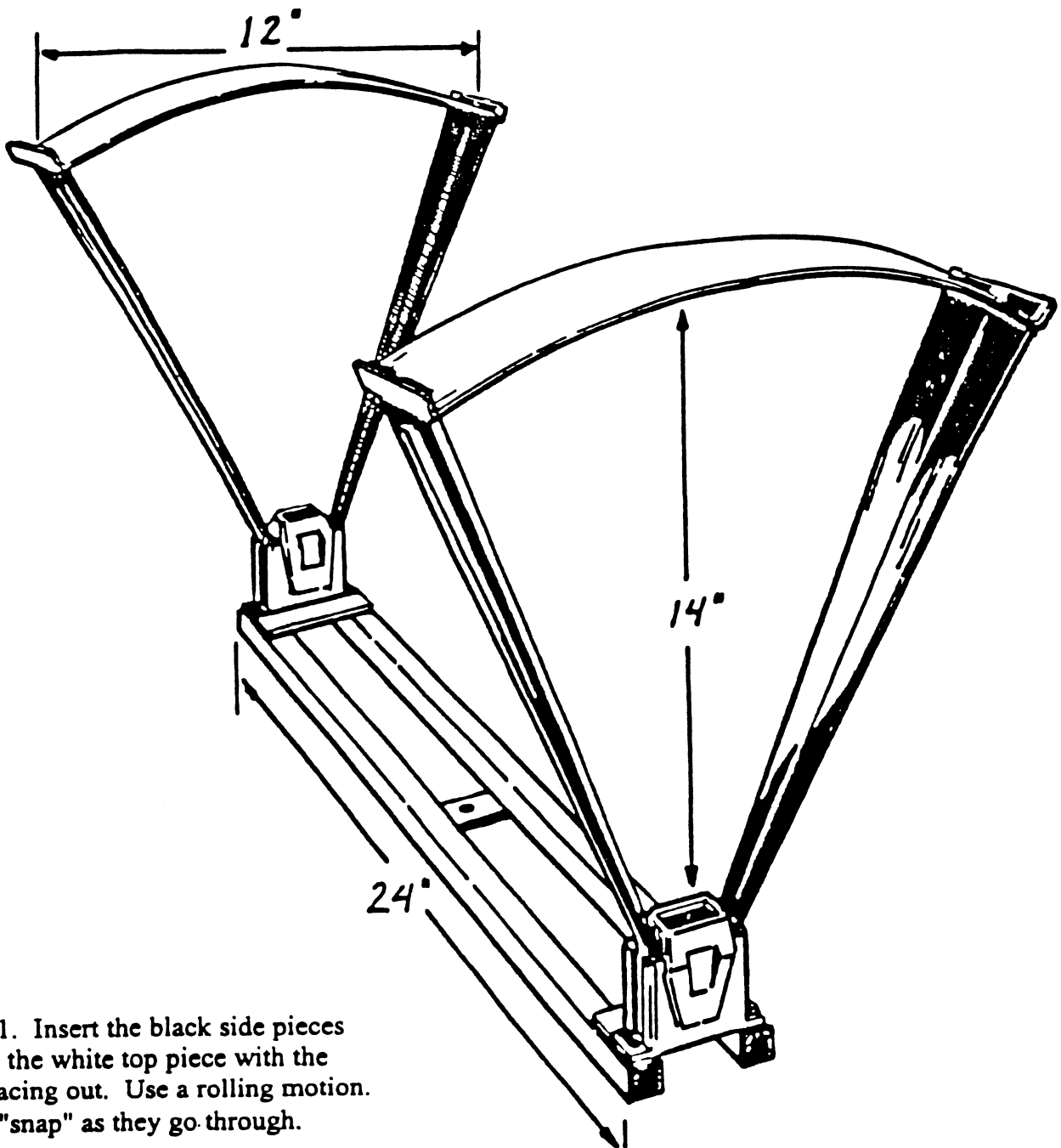

1. Insert the black side pieces through the white top piece with the hooks facing out. Use a rolling motion. They'll "snap" as they go through.

2. Lower the assembly into the skyscreen sensor housing as shown in the illustration.

3. On dark overcast days you may want to leave the top piece off.