



Potting Bench

Plan No. 910

Copyright U-Build, Inc., 2000.
All rights reserved. Printed in the U.S.A.

This do-it-yourself potting bench makes it easy to get a head start on warm-weather gardening. It features a generously-sized work top with a hutch above for tools, seeds and small pots. Below, shelves hold larger items, and a large compartment is just right for bulky bags of potting soil, fertilizer or a covered compost container. Best of all, the design is simple enough to build in a weekend or two, even if you're more gardener than woodworker.

The potting bench measures about 51 inches long by 24 inches deep by 65 inches tall.

Bill of Material

Quantity	Size	Material
4	1 1/2" x 3 1/2" x 10'	redwood, cedar or fir
7	5/8" x 5 3/8" x 10'	redwood, cedar or fir
54	#7 x 1 5/8"	wood screws
8	#8 x 2 1/2"	wood screws
28	#8 x 3"	wood screws
1 small box	1 1/4"	finish nails
1 small can		wood filler
1 small bottle		wood glue
1 quart		finish of choice

NOTES

1. Read all instructions and check materials before beginning work.
2. Read manufacturer's instructions before operating equipment.
3. **Always** wear safety glasses.
4. Although redwood is preferred for this project, cedar or fir may be substituted.

Cutting Schedule

Item	Qty	T	W	L	Material
A	2	1 1/2"	3 1/2"	36"	redwood, cedar or fir
B	2	1 1/2"	3 1/2"	65"	redwood, cedar or fir
C	4	1 1/2"	3 1/2"	21"	redwood, cedar or fir
D	2	1 1/2"	3 1/2"	21"	redwood, cedar or fir
E	1	1 1/2"	3 1/2"	45"	redwood, cedar or fir
F	1	1 1/2"	3 1/2"	48"	redwood, cedar or fir
G	1	1 1/2"	3 1/2"	18"	redwood, cedar or fir
H	3	5/8"	5 3/8"	45"	redwood, cedar or fir
I	2	5/8"	5 3/8"	27 7/8"	redwood, cedar or fir
J	2	5/8"	1"	11 11/16"	redwood, cedar or fir
K	2	5/8"	5 3/8"	23 1/4"	redwood, cedar or fir
L	4	5/8"	5 3/8"	50 1/2"	redwood, cedar or fir
M	1	5/8"	5 3/8"	50 1/2"	redwood, cedar or fir
N	3	5/8"	5 3/8"	45"	redwood, cedar or fir
O	2	5/8"	1"	16 1/8"	redwood, cedar or fir
P	2	5/8"	5 3/8"	45"	redwood, cedar or fir
Q	2	5/8"	5 3/8"	17 3/8"	redwood, cedar or fir
R	1	5/8"	4 3/4"	16 1/8"	redwood, cedar or fir
S	1	5/8"	4 3/4"	29"	redwood, cedar or fir

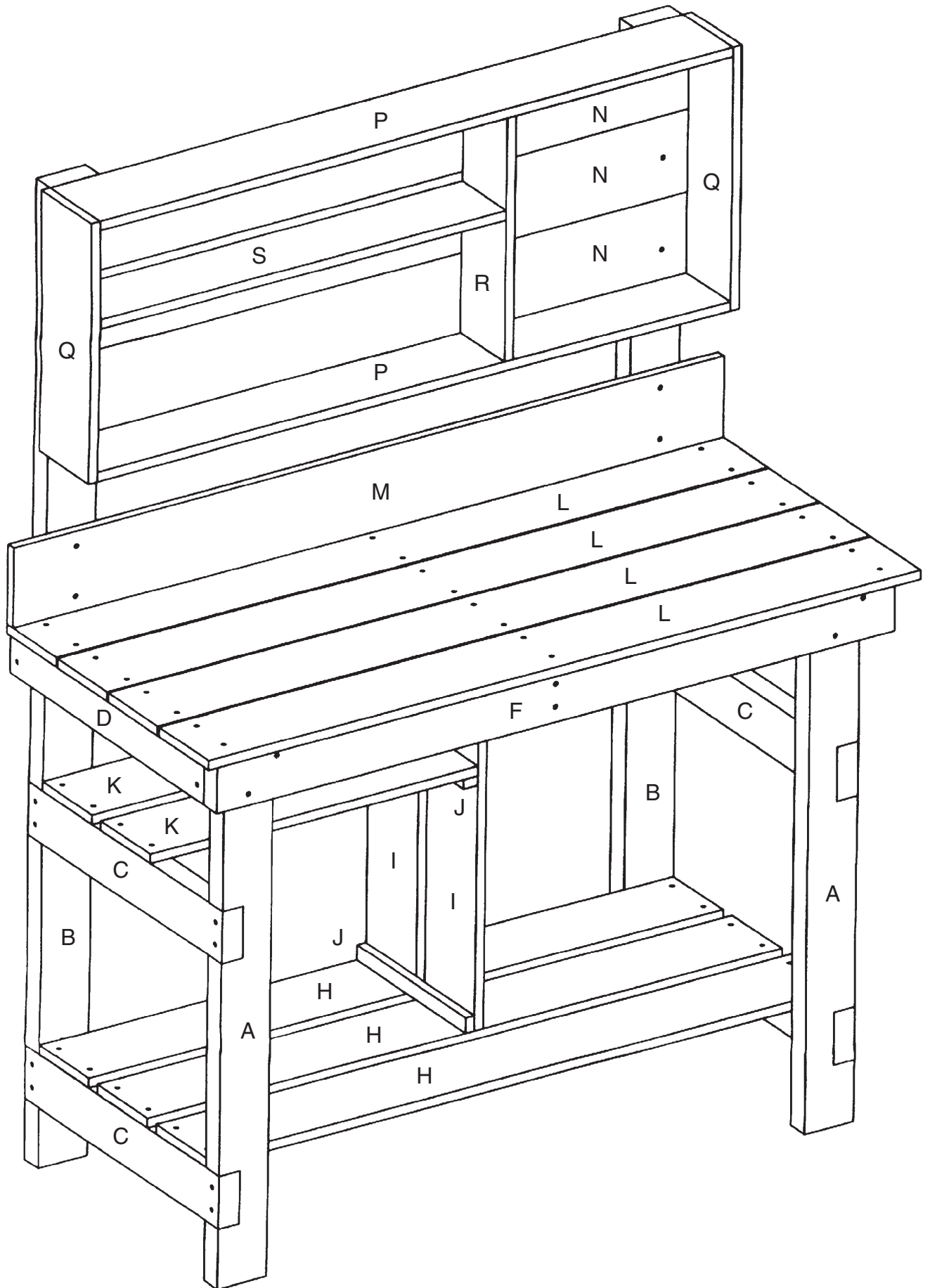

Construction Diagram 1
 (E, G and O not shown)

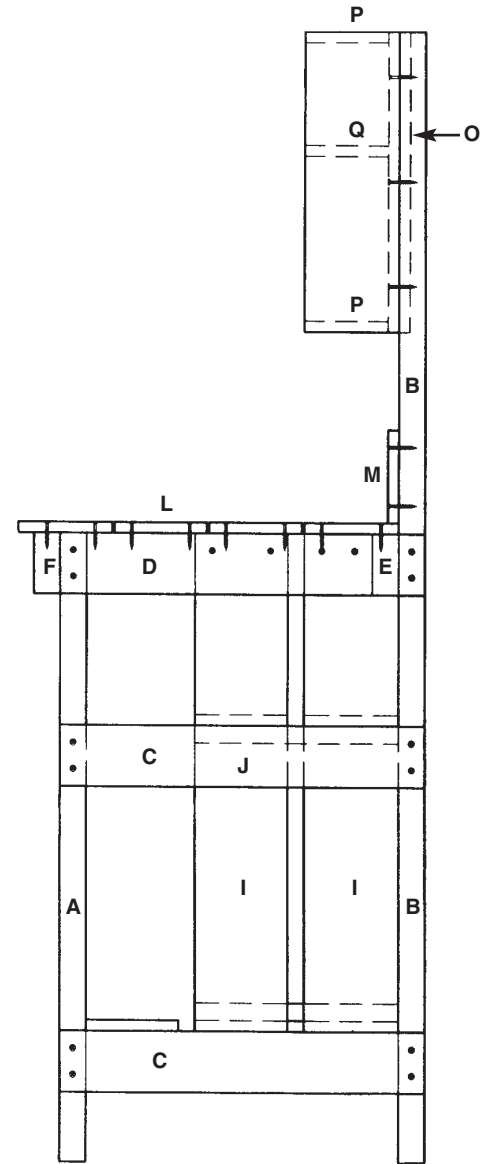
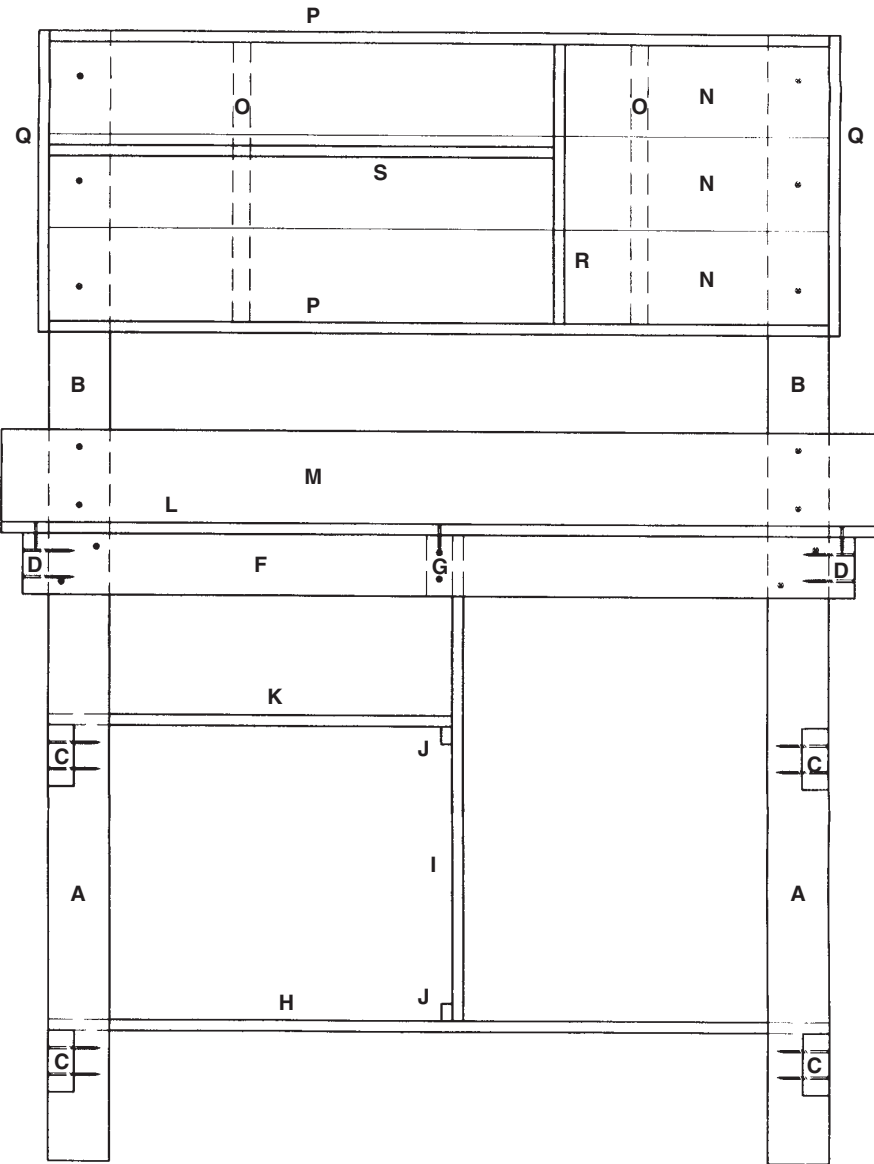
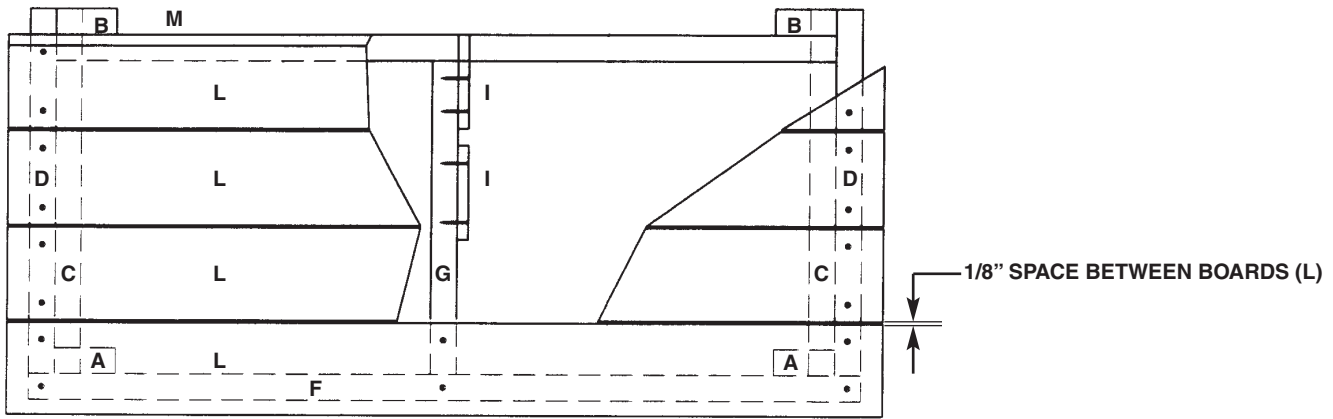

Construction Diagram 2

Assembly Instructions

Page One

Read all instructions before beginning any work. Cut all material to sizes shown in cutting schedule.

1. Drill holes in boards (C), (E), (F), (H) and (K). Refer to Figures 1 through 4.

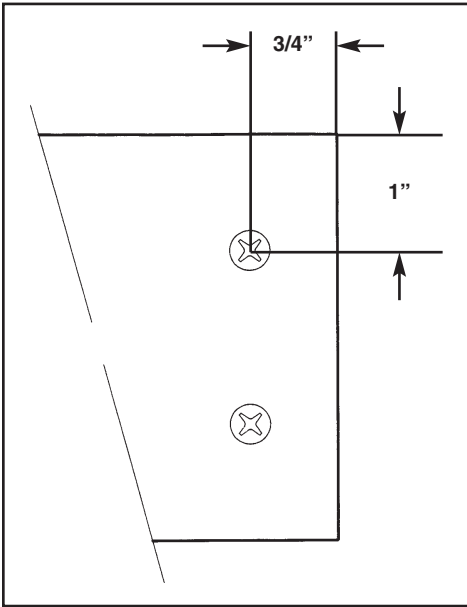

Figure 1
Boards C

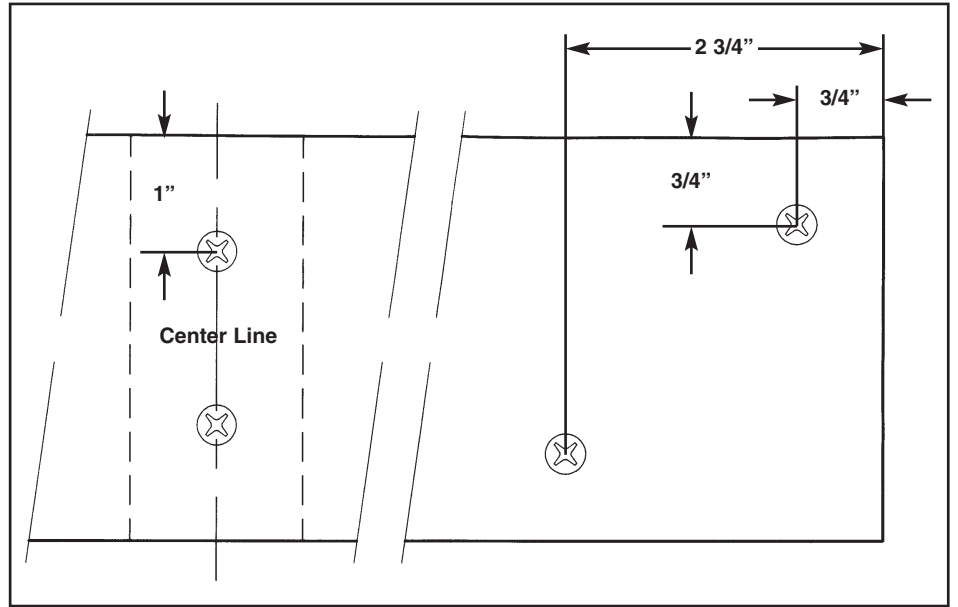

Figure 2
Board E

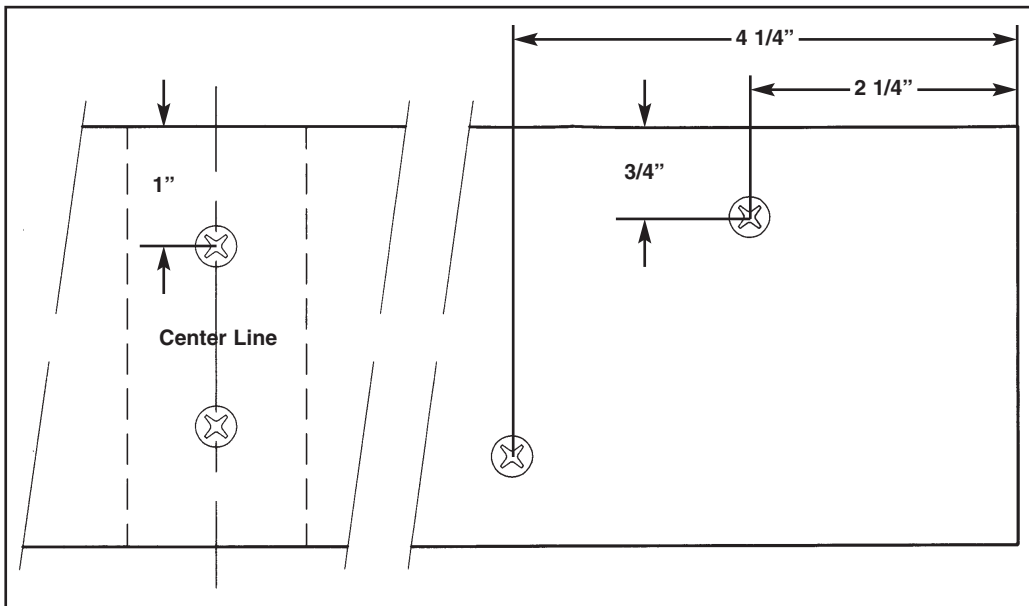

Figure 3
Board F

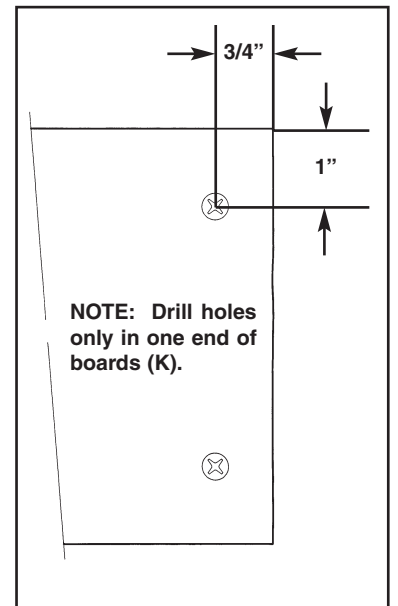

Figure 4
Boards H and K

Assembly Instructions

Page Two

Read all instructions before beginning any work. Cut all material to sizes shown in cutting schedule.

2. Drill holes in boards (L), (M) and (N). Refer to Figures 5 through 7.

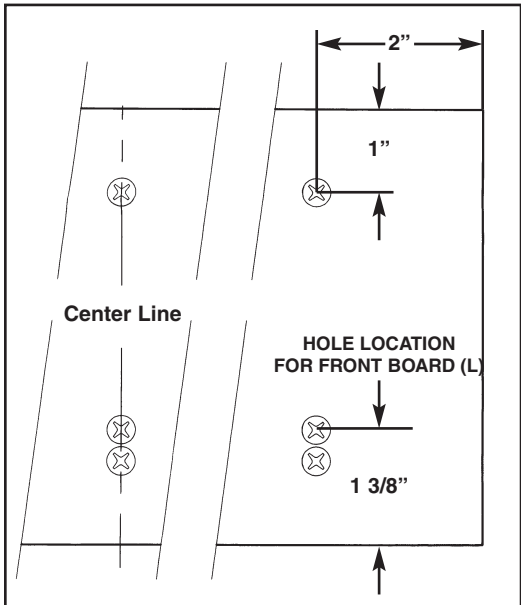

Figure 5
Boards L

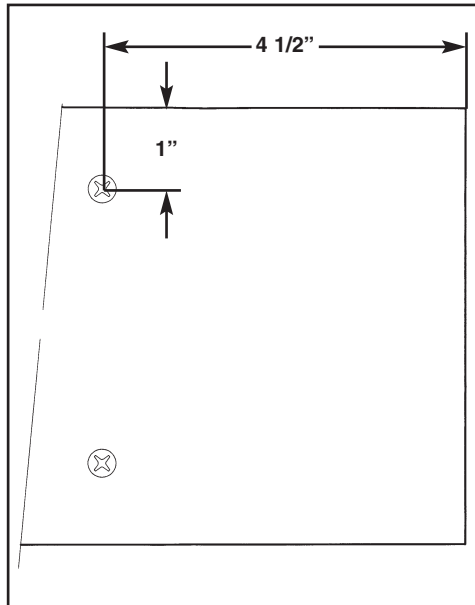

Figure 6
Board M

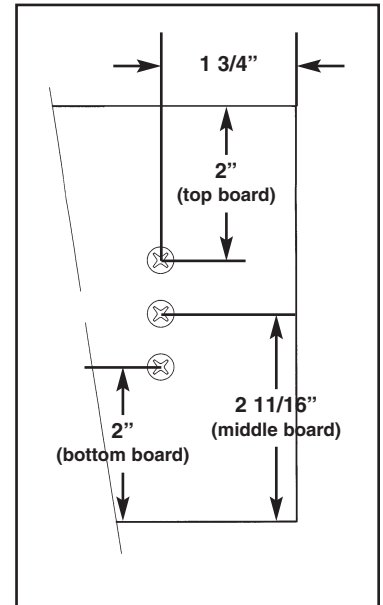

Figure 7
Boards N

3. Notch boards (A) and (B) for boards (C). See Figure 8.

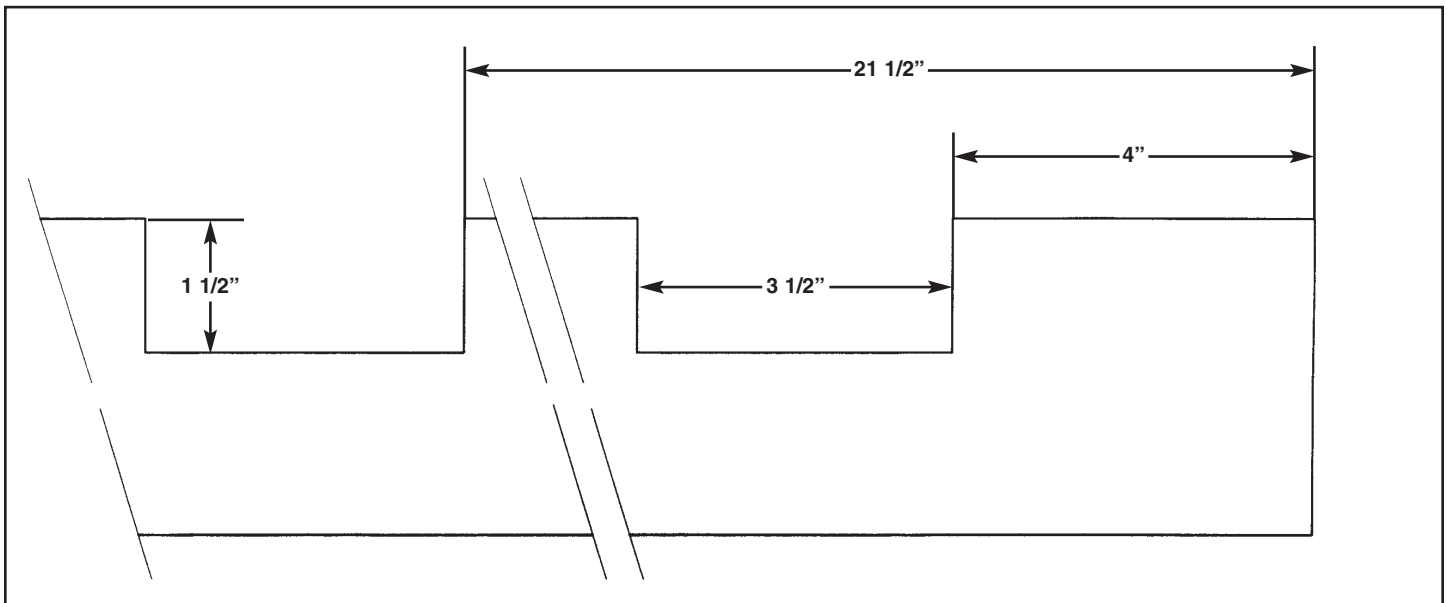

Figure 8
Boards A and B

Assembly Instructions

Page Three

Read all instructions before beginning any work. Cut all material to sizes shown in cutting schedule.

4. Drill holes in boards (I). Notch one of the (I) boards for board (E). Refer to Figure 9.

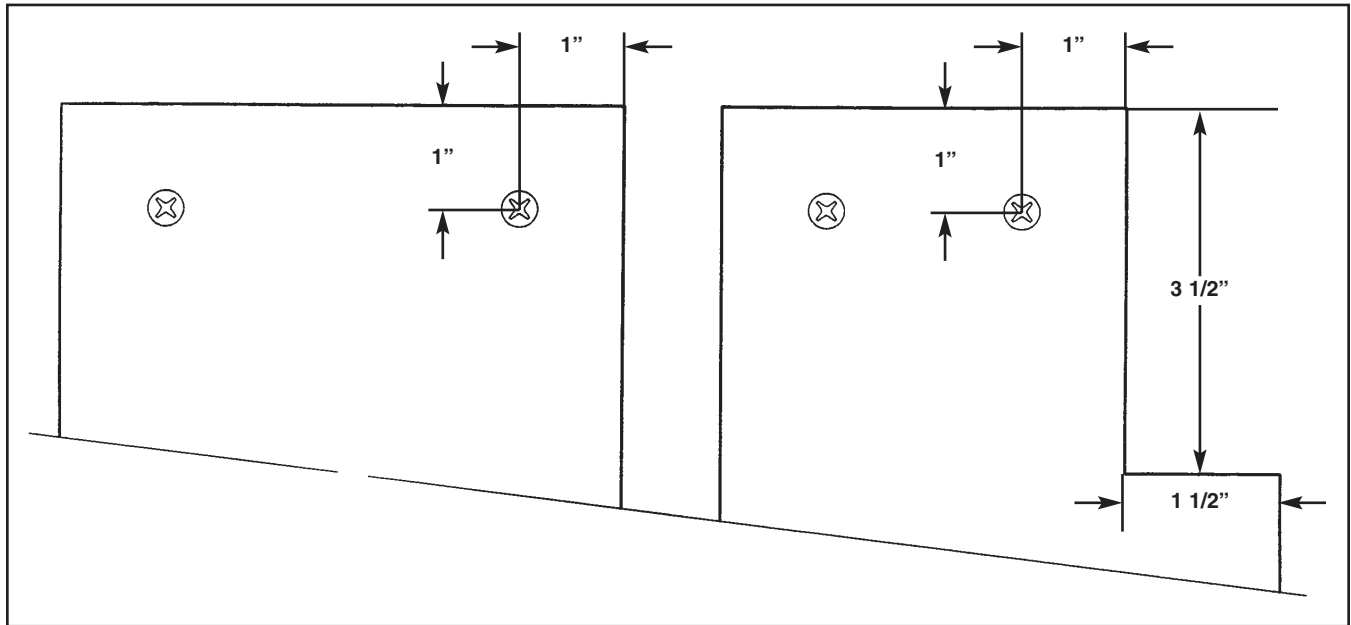

Figure 9
Boards I

NOTE: For steps 5 through 13, refer to Construction Diagrams 1 and 2. Check assembly for squareness after completing each step.

5. Attach boards (C) to boards (A) and (B) with 3" wood screws and glue.
6. Attach board (D) to (A) and (B) using 3" screws and glue.
7. Attach boards (E) and (F) to back and front of project using 2 1/2" wood screws and glue.
8. Use 3" wood screws and glue to attach (G) to (E) and (F).
9. Use 1 5/8" wood screws and glue to attach (I) to (G) and (K) to (C). Attach boards (J) to (I) and (H) using 1 1/4" finish nails and glue.
10. Attach bench top boards (L) and backboard (M) with 1 5/8" wood screws. Do not glue so that the bench top boards may be replaced.
11. Attach support boards (O) to the back of boards (N) using 1 1/4" finish nails and glue.
12. Assemble (P), (Q), (R) and (S) to (N) using glue and 1 1/4" finish nails.
13. Attach upper shelf assembly to boards (B) using 1 5/8" wood screws.